

DIN 8150 GALL ZİNCİRLERİ
DIN 8150 GALLE CHAINS

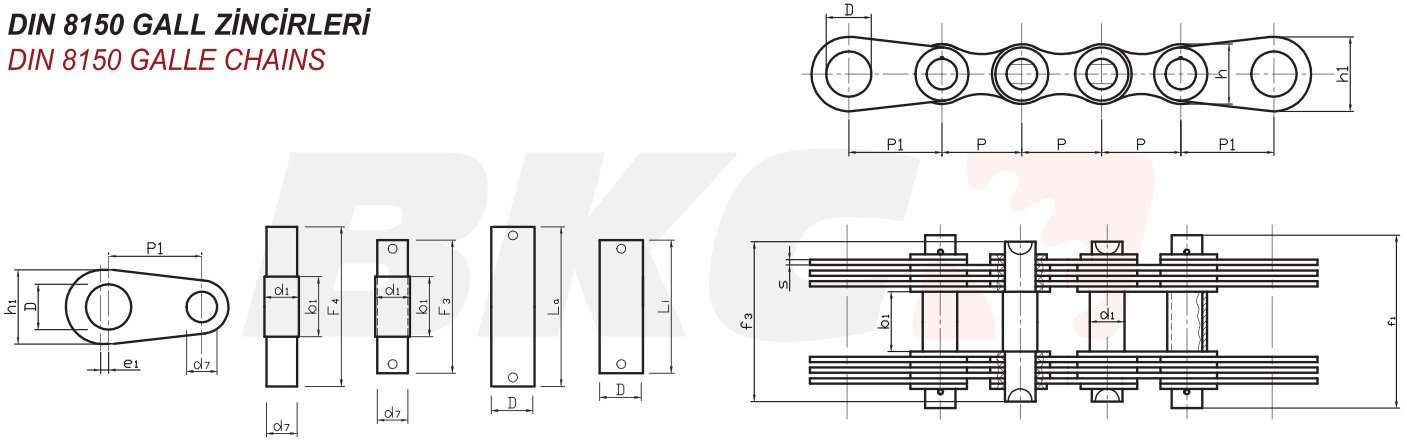

x Bakla dizim şekli x Combination

ISO Nr. ISO No.	p mm	p ₁ mm	b ₁ mm min.	d ₁ mm max.	d ₇ mm	D mm max.	e ₁ mm max.	F ₁ mm max.	F ₃ mm max.	F ₄ mm max.	h mm max.	h ₁ mm	L _a mm max.	L _i mm max.	s mm	x	F _B N min.	q kg/m
GZ 030	30	40	20	11	9	14	3,0	51	58	88	20	30	60	54	3	4	40000	3,1
GZ 035	35	45	22	12	10	16	3,5	53	61	93	26	35	62	55	3	4	60000	4,1
GZ 040	40	50	25	14	12	18	4,0	58	66	102	30	40	70	63	3	4	80000	5,0
GZ 045	45	55	30	17	14	22	4,5	63	70	108	35	45	75	68	3	4	100000	6,2
GZ 050	50	60	35	22	18	26	5,0	90	97	141	38	50	108	98	4,5	4	150000	10,9
GZ 055	55	65	40	24	21	32	5,5	108	115	163	40	55	132	118	6	4	200000	14,1
GZ 060	60	70	45	26	23	36	6,0	114	120	171	45	60	139	125	6	4	250000	17,2
GZ 070	70	85	50	32	28	40	7,0	148	157	213	55	70	169	156	6	6	375000	33,5
GZ 080	80	100	60	36	32	50	8,5	159	171	233	60	85	189	176	6	6	500000	38,2
GZ 090	90	120	70	40	36	60	10	184	200	266	70	100	214	199	7	6	750000	53,0
GZ 100	100	140	80	45	40	70	12	224	234	309	80	120	256	239	7	8	1000000	76,6
GZ 110	110	160	90	50	45	80	14	236	251	327	90	140	279	264	7	8	1250000	90,0
GZ 120	120	180	100	55	50	90	16	262	277	357	100	160	306	287	8	8	1500000	112

Numune ve teknik resim esaslı her türlü özel zincir üretimi yapılır. *Production based on a given sample or a technical drawing.*