

## DIN 8165 KAZIYICI KULAKLI ZİNCİRLER (FV SERİSİ) DIN 8165 SCRAPER CONVEYOR CHAINS (FV SERIES)

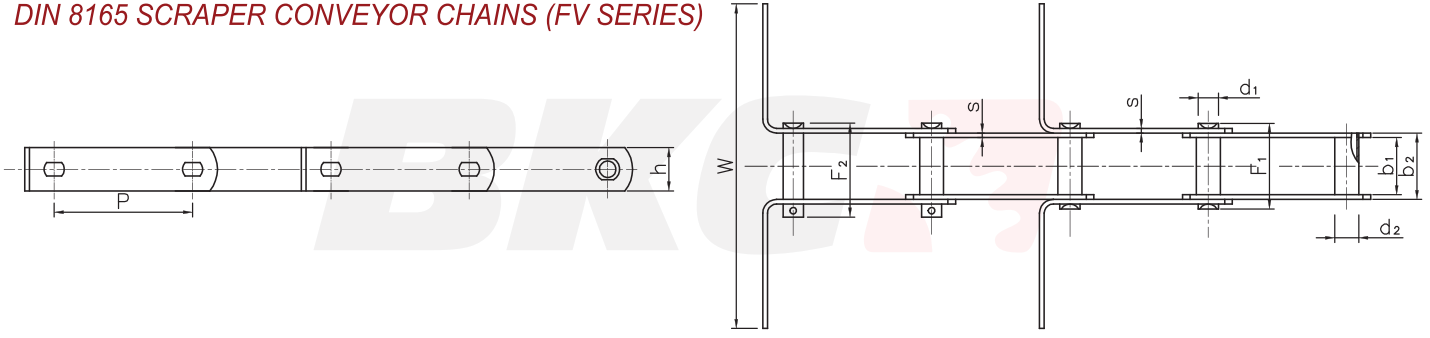

\*\* Sadece İstek Üzerine \*\* Only on request

ISO Nr. ISO No.	p mm	b <sub>1</sub> mm min.	b <sub>2</sub> mm max.	d <sub>1</sub> mm	d <sub>2</sub> mm	d <sub>3</sub> ** mm	F <sub>1</sub> mm	F <sub>2</sub> mm	h mm	s mm	W mm	F <sub>B</sub> N min.
FV 40	40 63 100	18	25	10	15	20	36	43	26	3	Serbest Ölçü Free Dimension	42000
FV 63	63 100 125 160	22	31	12	18	26	44	54	30	4	Serbest Ölçü Free Dimension	64000
FV 90	63 100 125 160 200 250	25	36	14	20	30	52	61	35	5	Serbest Ölçü Free Dimension	100000
FV 112	100 125 160 200 250	30	43	16	22	32	61	70	40	6	Serbest Ölçü Free Dimension	120000
FV 140	100 125 160 200 250 315	35	48	18	26	36	66	79	45	6	Serbest Ölçü Free Dimension	145000
FV 180	125 160 200 250 315 400	45	63	20	30	42	85,5	99	50	8	Serbest Ölçü Free Dimension	190000
FV 250	125 160 200 250 315 400	55	73	26	36	50	97,5	113	60	8	Serbest Ölçü Free Dimension	275000
FV 315	160 200 250 315 400	65	87	30	42	60	117	130	70	10	Serbest Ölçü Free Dimension	370000
FV 400	160 200 250 315 400	70	96	32	44	60	130	148	70	12	Serbest Ölçü Free Dimension	410000
FV 500	160 200 250 315 400	80	106	36	50	70	140	160	80	12	Serbest Ölçü Free Dimension	540000
FV 630	200 250 315 400 500	90	116	42	56	80	152	169	100	12	Serbest Ölçü Free Dimension	630000

Numune ve teknik resim esaslı her türlü özel zincir üretimi yapılır. *Production based on a given sample or a technical drawing.*

## DIN 8167 KAZIYICI KULAKLI ZİNCİRLER (M SERİSİ)

### DIN 8167 SCRAPER CONVEYOR CHAINS (M SERIES)

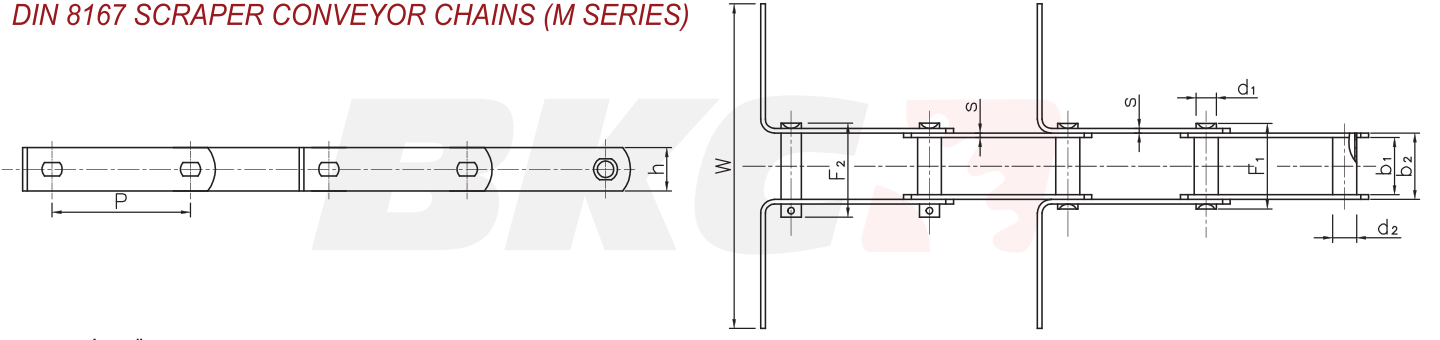

\*\* Sadece İstek Üzerine \*\* Only on request

ISO Nr. ISO No.	p mm		b <sub>1</sub> mm min.	b <sub>2</sub> mm max.	d <sub>1</sub> mm	d <sub>2</sub> mm	d <sub>3</sub> ** mm	F <sub>1</sub> mm	F <sub>2</sub> mm	h mm	s mm	W mm	F <sub>B</sub> N min.
M 20	40	50	16	22	6	9	12,5	31,2	36,2	18	2,5	Serbest Ölçü Free Dimension	20000
	63	80											
	100	125											
	160												
M 28	50	63	18	25	7	10	15	35,2	40,2	20	3	Serbest Ölçü Free Dimension	28000
	80	100											
	125	160											
	200												
M 40	63	80	20	28	8,5	12,5	18	40,2	47,2	25	3,5	Serbest Ölçü Free Dimension	40000
	100	125											
	160	200											
	250												
M 56	63	80	24	33	10	15	21	47,2	56,2	30	4	Serbest Ölçü Free Dimension	56000
	100	125											
	160	200											
	250												
M 80	80	100	28	39	12	18	25	55,2	64,2	35	5	Serbest Ölçü Free Dimension	80000
	125	160											
	200	250											
	315												
M 112	80	100	32	45	15	21	30	64,2	75,2	40	6	Serbest Ölçü Free Dimension	112000
	125	160											
	200	250											
	315	400											
M 160	100	125	37	52	18	25	36	73,3	88,3	50	7	Serbest Ölçü Free Dimension	160000
	160	200											
	250	315											
	400	500											
M 224	125	160	43	60	21	30	42	86,3	99,3	60	8	Serbest Ölçü Free Dimension	224000
	200	250											
	315	400											
	500	630											
M 315	160	200	48	70	25	36	50	100,3	120,3	70	10	Serbest Ölçü Free Dimension	315000
	250	315											
	400	500											
	630												
M 450	200	250	56	82	30	42	60	117,3	141,3	80	12	Serbest Ölçü Free Dimension	450000
	315	400											
	500	630											
	800												
M 630	250	315	66	96	36	50	70	136,3	159,3	100	14	Serbest Ölçü Free Dimension	630000
	400	500											
	630	800											
	1000												
M 900	250	315	78	112	44	60	85	157,3	179,3	120	16	Serbest Ölçü Free Dimension	900000
	400	500											
	630	800											
	1000												

Numune ve teknik resim esaslı her türlü özel zincir üretimi yapılır. *Production based on a given sample or a technical drawing.*